

# GRAZER TUBE SM

SURFACE MOUNTED PROFILE

# DARKON

THE EDGE OF LIGHT

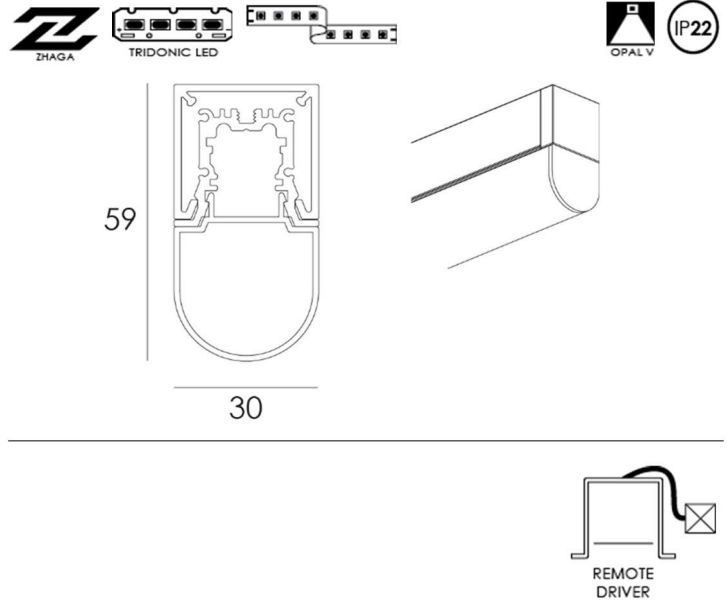

## DESIGN FEATURES

- Dot free homogeneous illumination
- Screwless end caps
- Multiple fixed output options
- Up to 82 exit lumens per system watt
- 90+ colour rendering, 80+ available upon request
- High colour tolerance - MacAdam 3
- Complies with AS/NZS 60598.2.1

## INSTALLATION FEATURES

- Detailed shop drawings
- Australian made
- Supplied 100% pre-built
- 5 year warranty
- 10 year extended warranty optional
- Project specific labelling referencing type numbers
- Approximate fitting weight of 1.2 Kg per/m.
- Miter joins are not available

## LUMEN PERFORMANCE

### TRIDONIC FIXED WHITE / EXIT LUMENS

HE CRI90	200mA	1060 lm p/mtr	13 W p/mtr
HE CRI90	250mA	1309 lm p/mtr	16 W p/mtr
HE CRI90	300mA	1549 lm p/mtr	19 W p/mtr
HE CRI90	350mA	1783 lm p/mtr	22 W p/mtr
HE CRI90	400mA	2007 lm p/mtr	26 W p/mtr
HE CRI90	450mA	2210 lm p/mtr	29 W p/mtr
HE CRI90	500mA	2418 lm p/mtr	32 W p/mtr

Tested with white finish @ 4000K with Opal V lens.

## CONFIGURATOR

**INT FINISH:** Black / White / Silver

**EXT FINISH:** Black / White / Silver

**LENS:** Opal V

**LED:** HE / DPAL20 / DPAL60 / RGBW HE / RGBW HO

**CURRENT:** 200 / 250 / 300 / 350 / 400 / 450 / 500mA

**TEMP:** 2700K / 3000K / 4000K

**DIMMING:** Non dim / DALI dim / SwitchDIM / DSI dim

PROJECT:

TYPE NO:

QTY:

REV: 9/06/2023

DARKON.COM.AU