

TUBE

SURFACE MOUNTED PROFILE

DARKON™
THE EDGE OF LIGHT

Ensure that products are mounted with supplied, recommended or appropriate screws and fixings to suit the mounting surface.

WARNING

INSTALLATION IS ONLY TO BE CARRIED OUT BY SUITABLY QUALIFIED PERSONS IN ACCORDANCE WITH INSTALLATION INSTRUCTIONS AND ALL APPLICABLE REGULATIONS OR STANDARDS. (IMPROPER INSTALLATION CAN CREATE AN ELECTRICAL HAZARD WITH RISK OF ELECTRIC SHOCK, FIRE OR INJURY). DARKON WILL NOT BE HELD RESPONSIBLE FOR ANY CONSEQUENCES ARISING FROM IMPROPER PRODUCT HANDLING, STORAGE OR INSTALLATION.

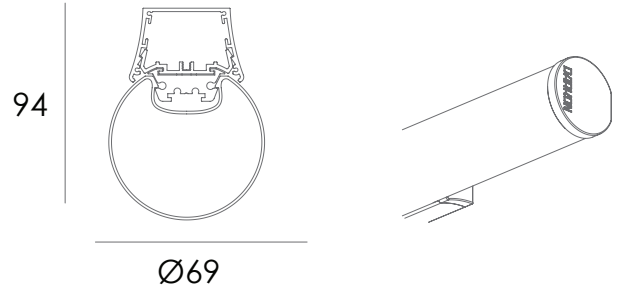

TOOLS REQUIRED

POWER DRILL / DRILL BIT / PHILLIPS DRIVER / PENCIL / PLIERS / TAPE MEASURE / PLUM LASER

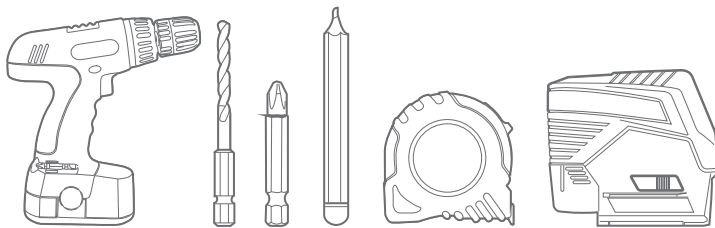

MAINTENANCE



Wipe product with a clean dry microfiber cloth. Do not use any cleaning products/ chemicals to clean product.

SERVICING

THIS IS A NON-SERVICEABLE FITTING. REMOTE POWER SUPPLY CAN BE REPLACED IF DEEMED FAULTY.

COMPONENTS



A

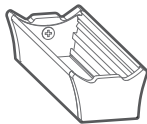

B



C

	DISTANCE	DESCRIPTION
A)	150MM	MOUNTING LOCATION
B)	PROFILE LENGTH 2	3RD MOUNTING LOCATION
C)	45	POWERFEED LOCATION

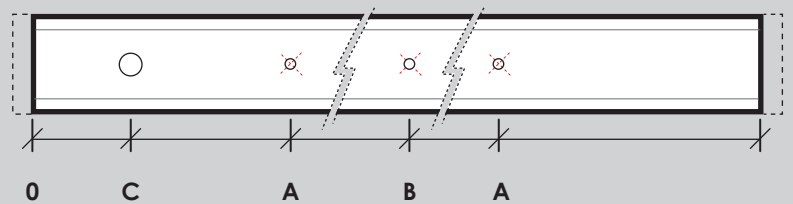

MINIMUM AREA REQUIREMENT
FIGURE 1.



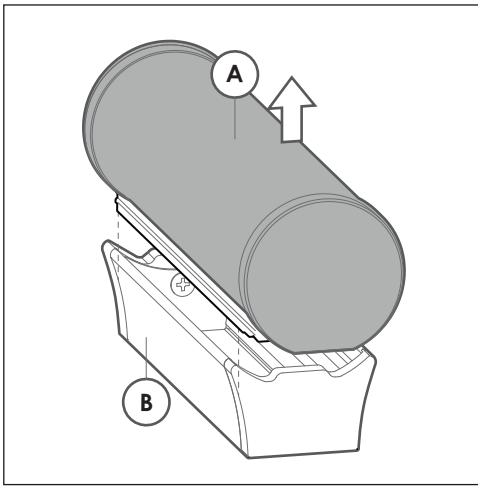

1. Unassemble **Tube lens assembly(A)** from **Surfacebody(B)**

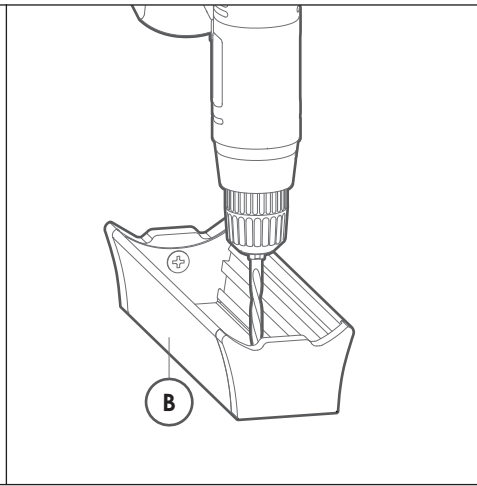

2. Drill appropriate sized clearance holes for fasteners on **Surfacebody(B)**
See Figure 1 for reference.

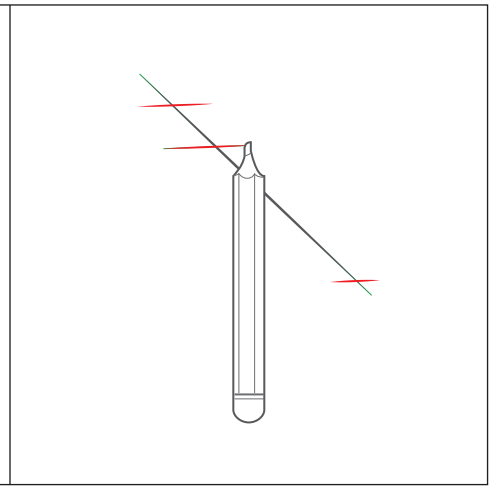

3. Project line using laser plumb and mark necessary mounting points
See Figure 1 for reference.

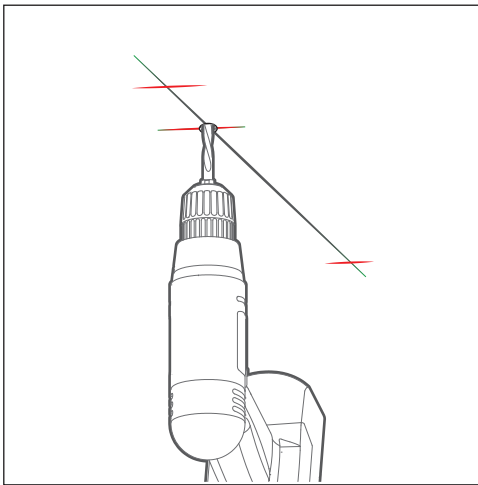

4. Drill all necessary holes on ceiling.

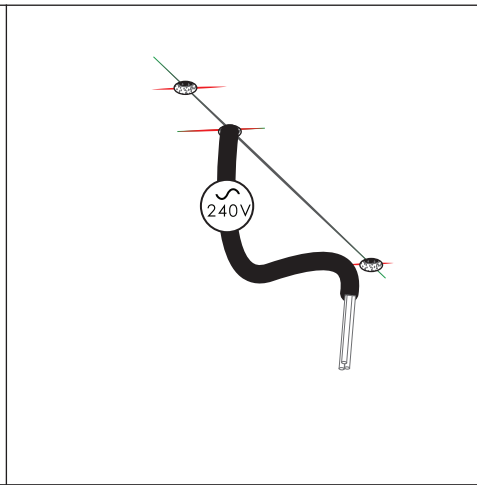

5. Pull power cable(240V) through cutout.

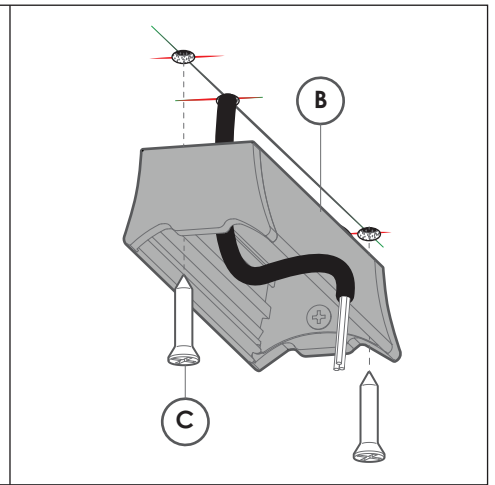

6. Fix the **Surfacebody(B)** onto the ceiling with appropriate fasteners (*not supplied*).

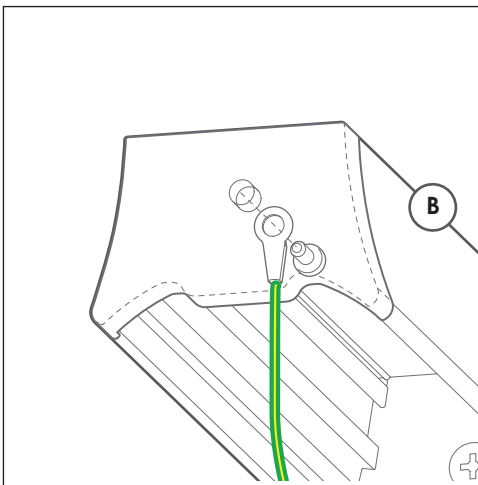

7. Fasten earth lug to threaded detail on endcap.

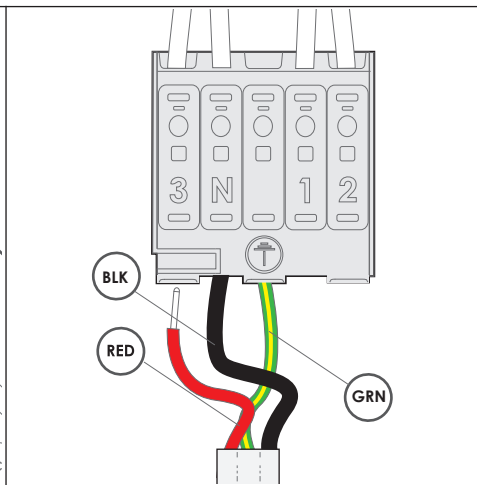

8. Wire primary wires into terminal.

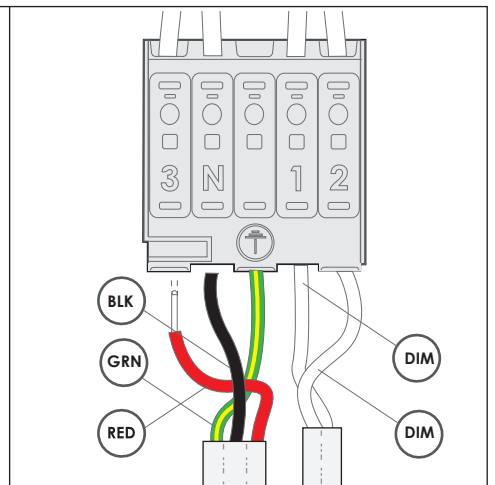

9. Wire primary wires into terminal
Wire dimming wires into terminal.

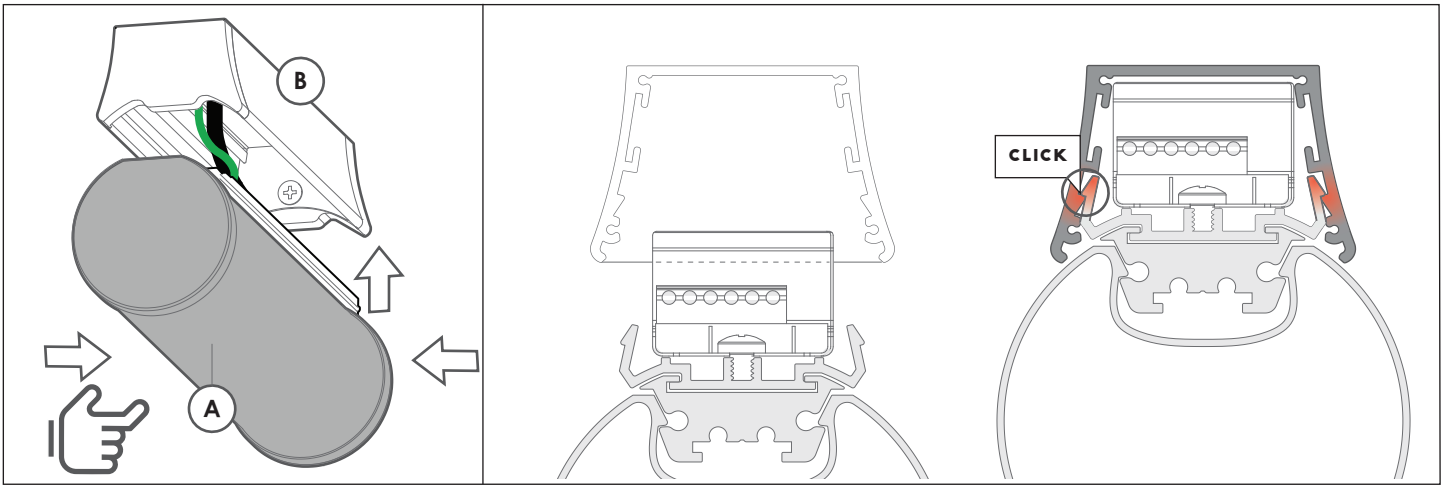

8. Install **Tube lens assembly (A)** to **Surfacebody (B)**. Apply gentle pressure to the sides of the tube lens to help it seat inside the Surfacebody.

9. Ensure proper installation by clipping Mainbody to Surfacebody snap-fit detail. Centre **Tube lens assembly (A)**.