

GRAZER / GRAZER TUBE

RECESSED LUMINAIRE

DARKON™
THE EDGE OF LIGHT

Ensure that products are mounted with supplied, recommended or appropriate screws and fixings to suit the mounting surface.

WARNING

INSTALLATION IS ONLY TO BE CARRIED OUT BY SUITABLY QUALIFIED PERSONS IN ACCORDANCE WITH INSTALLATION INSTRUCTIONS AND ALL APPLICABLE REGULATIONS OR STANDARDS. (IMPROPER INSTALLATION CAN CREATE AN ELECTRICAL HAZARD WITH RISK OF ELECTRIC SHOCK, FIRE OR INJURY). DARKON WILL NOT BE HELD RESPONSIBLE FOR ANY CONSEQUENCES ARISING FROM IMPROPER PRODUCT HANDLING, STORAGE OR INSTALLATION.

TOOLS REQUIRED

SCREW DRIVER / PENCIL / WALLBOARD SAW / APPROPRIATE MEASURING INSTRUMENTS / LASER PLUM

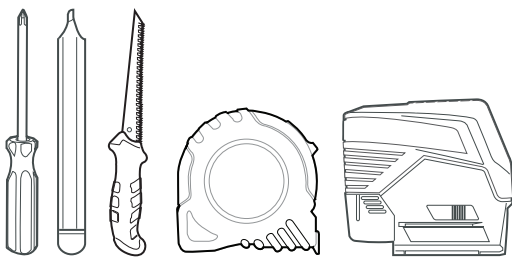

COMPONENTS

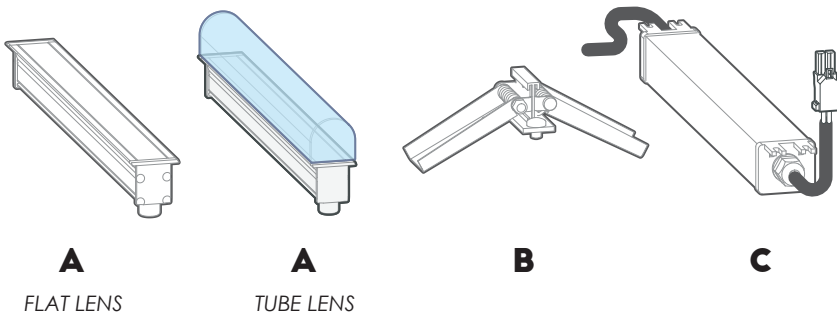

FLAT LENS

TUBE LENS

B

C

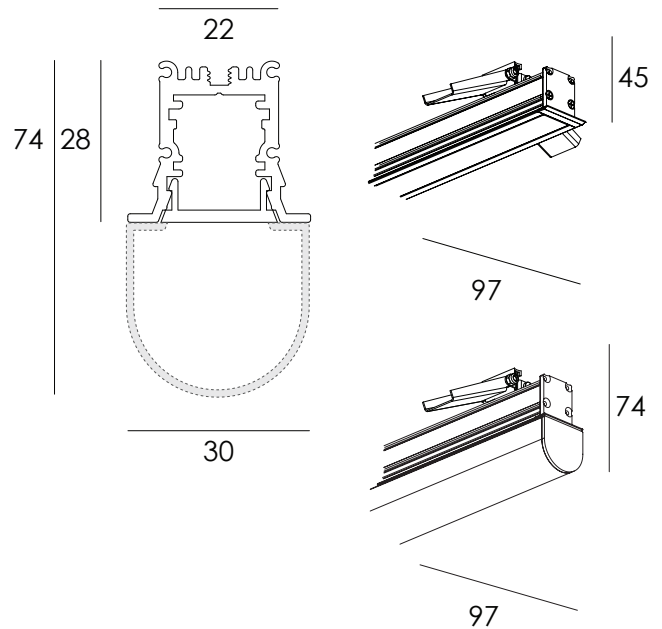

REMOTE DRIVER IS WIDER THAN PROFILE,
ALTERNATE ACCESS PANEL REQUIRED.

MAINTENANCE



Wipe product with a clean dry microfiber cloth.
Do not use any cleaning products/ chemicals to clean product.

SERVICING

'Remote Driver' can be replaced if deemed faulty.

DISTANCE

DESCRIPTION

A)	70MM (MINIMUM)	CLEARANCE FROM TOP OF FITTING (BRACKET UPRIGHT)
B)	16MM (MAX)	MAXIMUM WALLBOARD THICKNESS
C)	50MM (MINIMUM)	CLEARANCE FOR SPRING CLIP
D)	LENGTH LESS 8MM	LENGTH CUTOUT
E)	23MM	WIDTH CUTOUT

FIGURE 1. CRITICAL DIMENSIONS

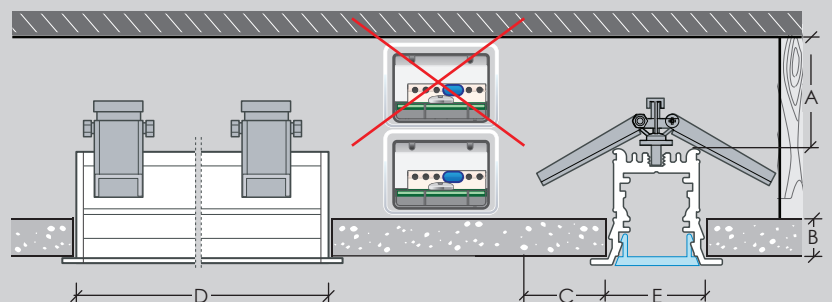

FOR OPTIMAL LONGEVITY, ENSURE UNRESTRICTED AIRFLOW OVER LUMINAIRE & REMOTE DRIVER.
DO NOT COVER LUMINAIRE OR DRIVER WITH INSULATION. DO NOT STACK DRIVERS.



12.07.22

www.darkon.com.au

1/2

REVISION 04

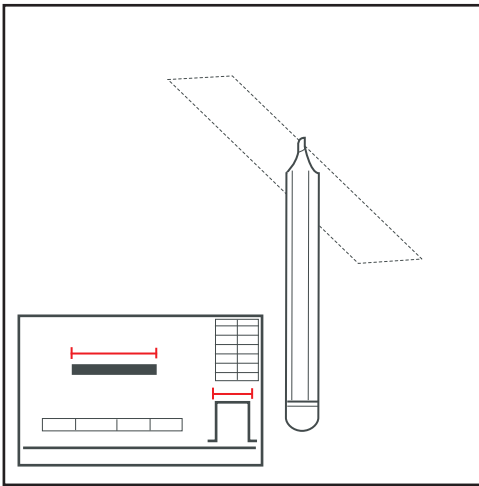

1. Utilising supplied Darkon Shop drawing, measure and mark position of light fitting.
See FIGURE 1.

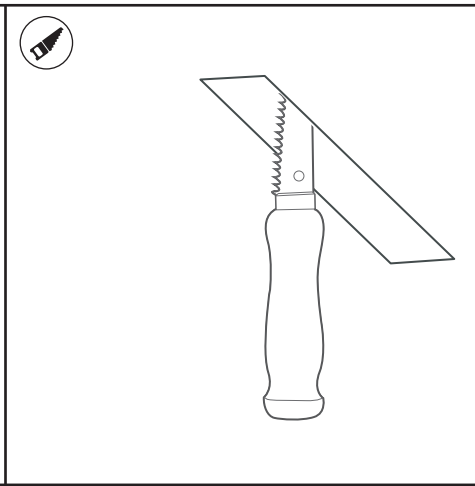

2. Make cut-out using a Wallboard Saw.

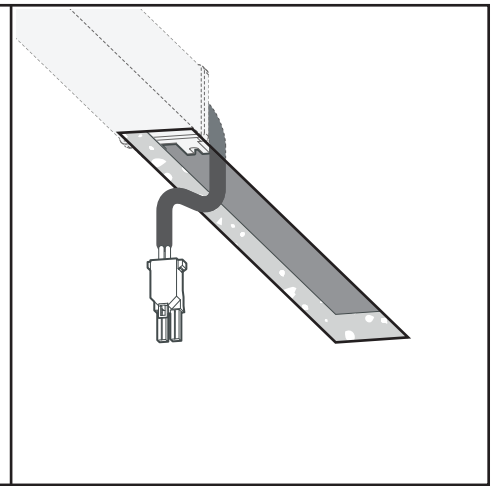

3. Install driver and feed secondary cable through cutout.

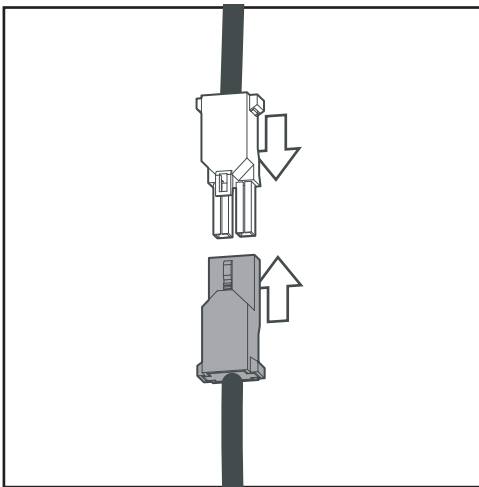

4. Connect appropriate plugs.

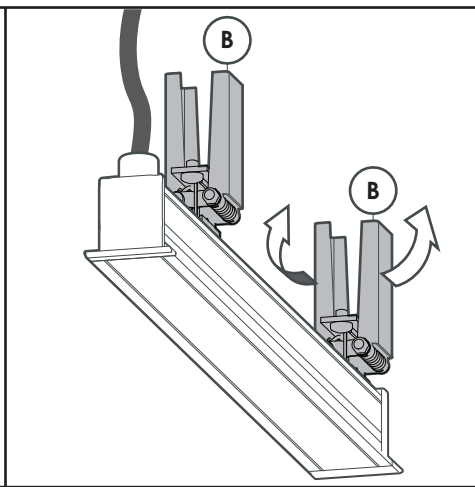

5. Bend Spring Clips(B) backwards.

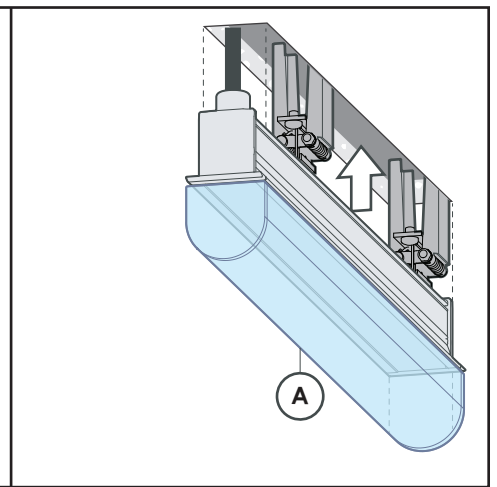

6. Keep Spring Clips(B) upright and insert Recessed body(A) into cut out.

MITRES ONLY APPLICABLE FOR GRAZER FLAT LENS

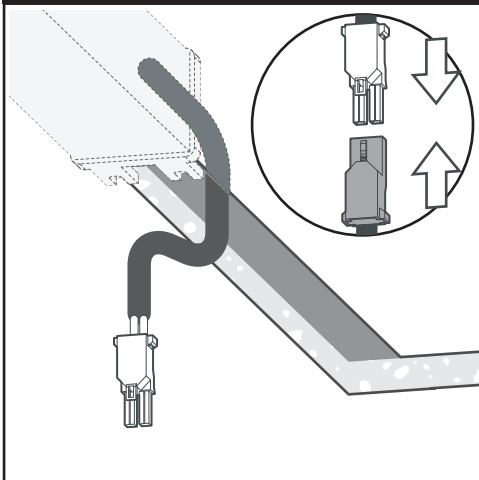

7. Make the cut-out using a Wallboard Saw with appropriate mitre detail. Install driver and terminate secondary cable by connecting plugs.

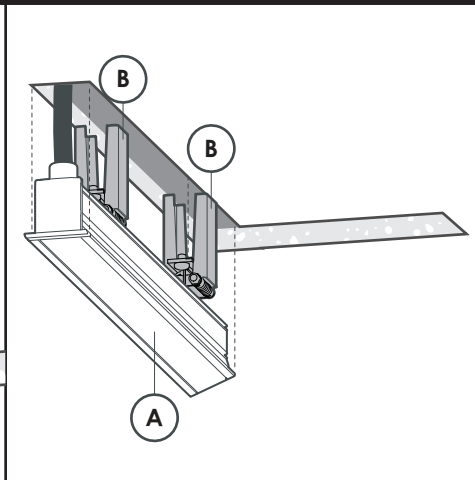

8. Bend Spring clips(B) backwards. Keep Spring Clips(B) upright and insert first Recessed body(A) into cut out.

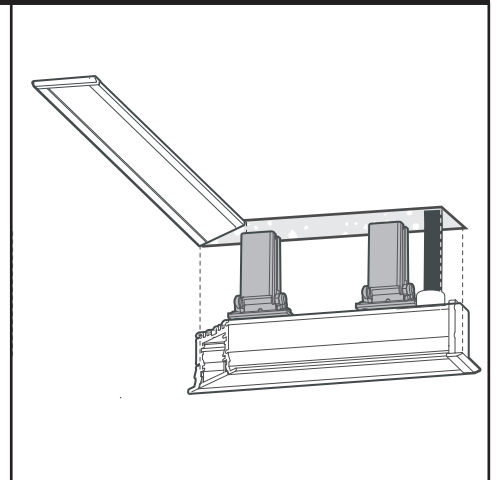

9. Repeat step 7 by connecting second Recessed body(A) to additional driver. Bend spring clips(B) backwards and insert second Recessed body(A) into cutout.