

PENNY ADJ SINGLE IT

WALL LIGHT

DARKON™
THE EDGE OF LIGHT

Ensure that products are mounted with supplied, recommended or appropriate screws and fixings to suit the mounting surface.

WARNING

INSTALLATION IS ONLY TO BE CARRIED OUT BY SUITABLY QUALIFIED PERSONS IN ACCORDANCE WITH INSTALLATION INSTRUCTIONS AND ALL APPLICABLE REGULATIONS OR STANDARDS. (IMPROPER INSTALLATION CAN CREATE AN ELECTRICAL HAZARD WITH RISK OF ELECTRIC SHOCK, FIRE OR INJURY). DARKON WILL NOT BE HELD RESPONSIBLE FOR ANY CONSEQUENCES ARISING FROM IMPROPER PRODUCT HANDLING, STORAGE OR INSTALLATION.

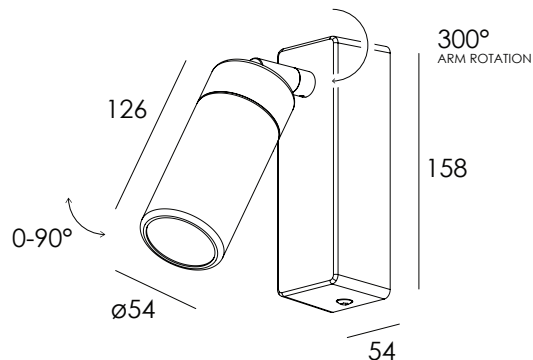

TOOLS REQUIRED

POWER DRILL / DRILL BIT / PHILLIPS DRIVER / PENCIL / SCREWDRIVER

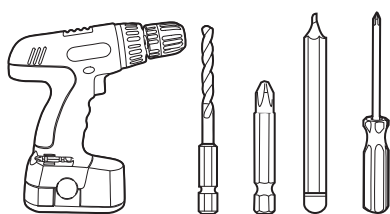

MAINTENANCE



Wipe product with a clean dry microfiber cloth. Do not use any cleaning products/ chemicals to clean product.

SERVICING

-This is a non-servicable fitting. Integral powersupply can be replaced if deemed faulty.

COMPONENTS

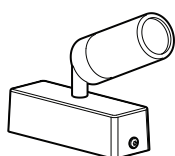

A

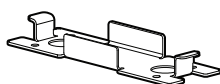

B

SUPPLIED PART

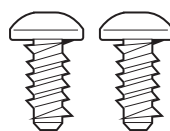

SUPPLIED FIXING QTYX2 M5X12 HEX BOLT

NOTE:

-It is the installer's responsibility to ensure the cable entry into the base is sealed correctly - care should be taken to ensure water can not enter along supply cable or via the mounting screws.

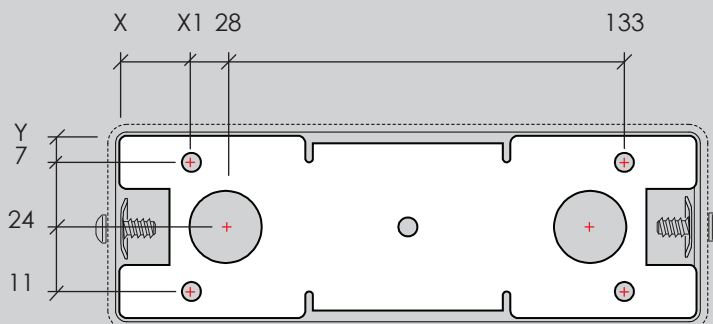

FIGURE 1. MOUNTING BRACKET CRITICAL DIMENSIONS



14.02.19

www.darkon.com.au

1/2

REVISION 01

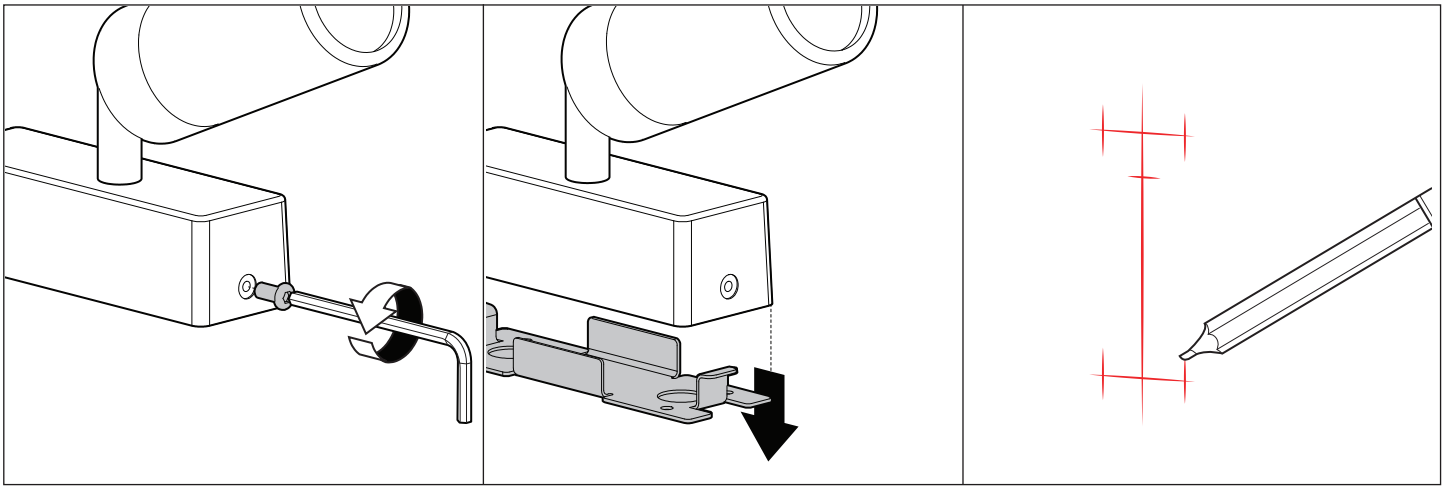

1.
-Remove fasteners using 3mm allen key.
Retain fasteners.

2.
-Remove mounting bracket(B) from
backbox(A)

3.
-Measure and mark the appropriate
placement of luminaire.
Refer to **FIGURE A** for critical dimensions.

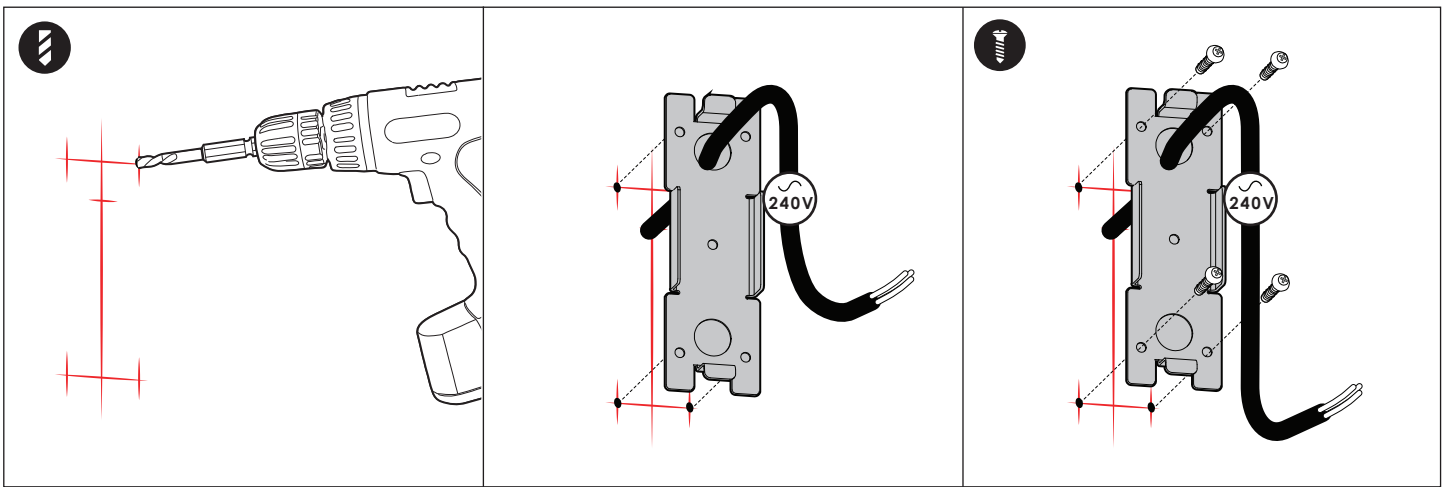

4.
-Using appropriate sized drill bit, drill hole for
powerfeed and pilot holes(if necessary)

5.
-Thread powercable(240V) through entry.

6.
-Using appropriate fasteners, fix bracket onto
wall (fasteners not supplied).
Ensure a firm seal of the bracket(B) against
the underlying surface.

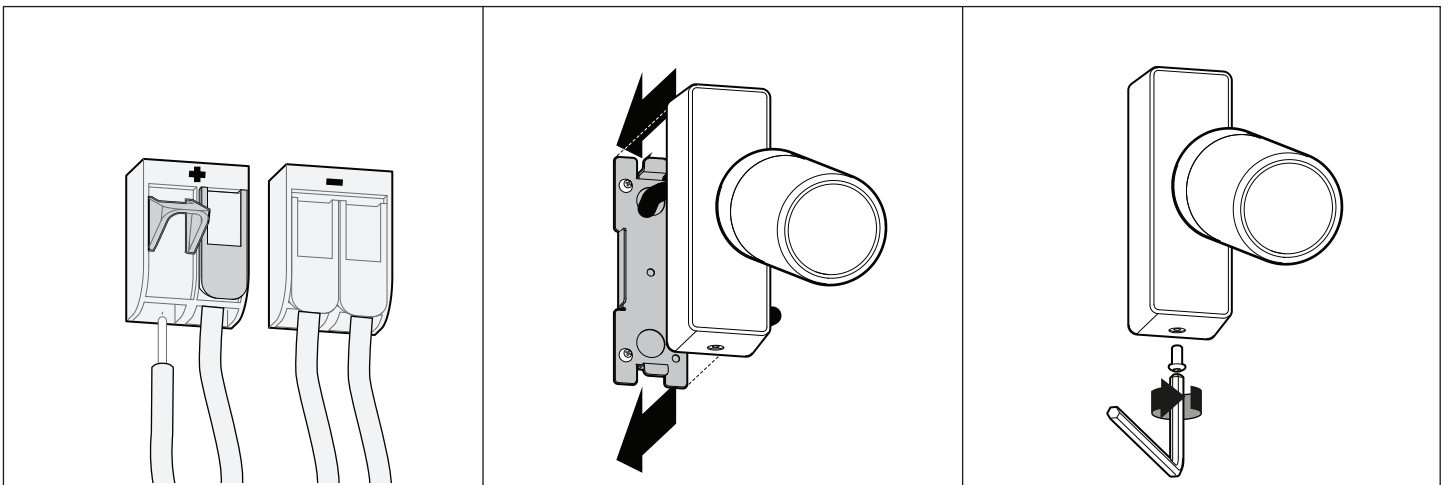

7.
-Open Wago terminal block &
connect wires.
Close Wago terminal block.

8.
-Place backbox over bracket

9.
-Fix with retained fastener using a M3 allen
key.