

TUBE

SUSPENDED PROFILE

DARKON™

THE EDGE OF LIGHT

Ensure that products are mounted with supplied, recommended or appropriate screws and fixings to suit the mounting surface.

WARNING

INSTALLATION IS ONLY TO BE CARRIED OUT BY SUITABLY QUALIFIED PERSONS IN ACCORDANCE WITH INSTALLATION INSTRUCTIONS AND ALL APPLICABLE REGULATIONS OR STANDARDS. (IMPROPER INSTALLATION CAN CREATE AN ELECTRICAL HAZARD WITH RISK OF ELECTRIC SHOCK, FIRE OR INJURY). DARKON WILL NOT BE HELD RESPONSIBLE FOR ANY CONSEQUENCES ARISING FROM IMPROPER PRODUCT HANDLING, STORAGE OR INSTALLATION.

TOOLS REQUIRED

POWER DRILL / DRILL BIT / PHILLIPS DRIVER / PENCIL / PLIERS / TAPE MEASURE / PLUM LASER

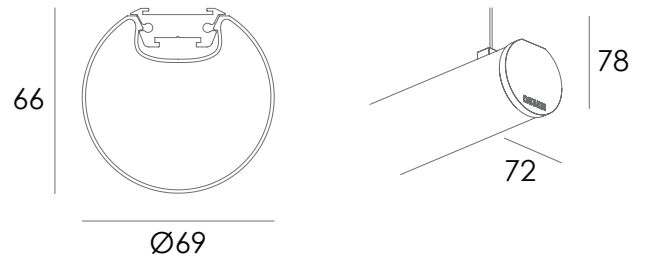
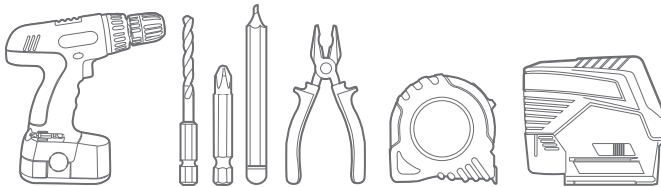

MAINTENANCE



Wipe product with a clean dry microfiber cloth. Do not use any cleaning products/ chemicals to clean product.

SERVICING

This is a non servicable fitting. Remote powersupply can be replaced if deemed faulty.

NOTE

-Lengths that exceed 2200mm are fitted with 4 suspensions adding to components G, H, & I.

REC

CUT OUT

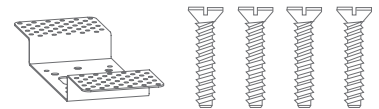

SUPPLIED IF REC CEILING PLATE*

COMPONENTS

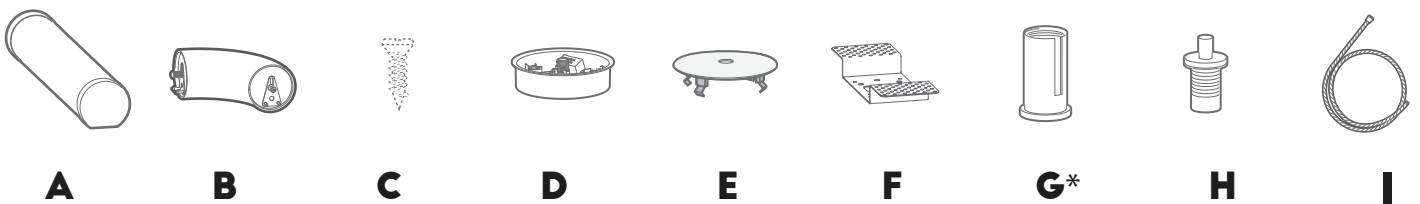

DISTANCE	DESCRIPTION
A) 15MM	SUSPENSION LOCATION
B) $\frac{\text{PROFILE LENGTH}}{2}$	3RD SUSPENSION LOCATION
C) 45	POWERFEED LOCATION
D) $\frac{\text{PROFILE LENGTH}}{3}$	4TH SUSPENSION LOCATION

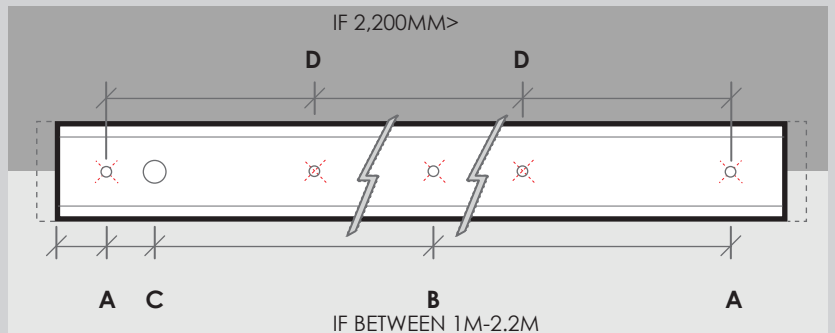

MINIMUM AREA REQUIREMENT
FIGURE 1.

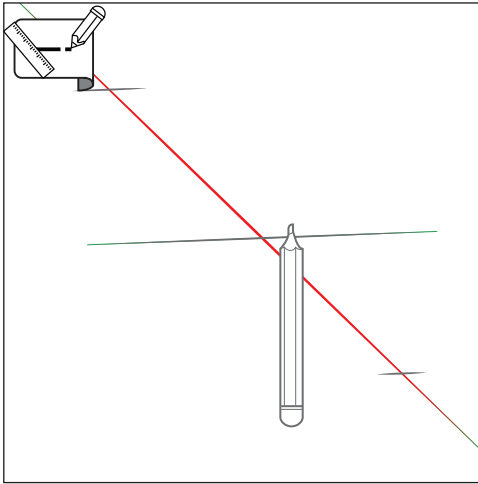

1.
Project line using laser plumb and mark necessary mounting points using supplied Darkon drawing as reference.

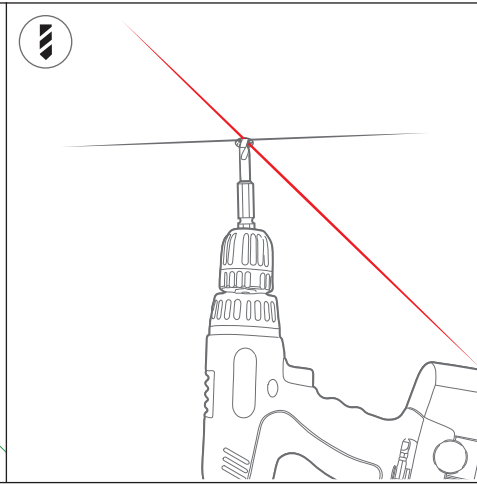

2A IF SM CEILING PLATE
Drill hole for powerfeed, drill pilot holes if necessary.

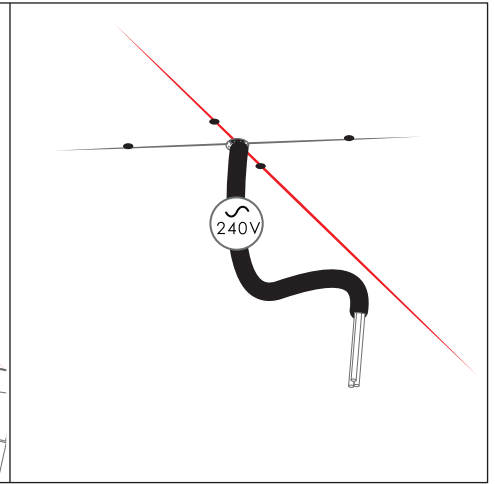

3A IF SM CEILING PLATE
Pull powercable(240V) through ceiling

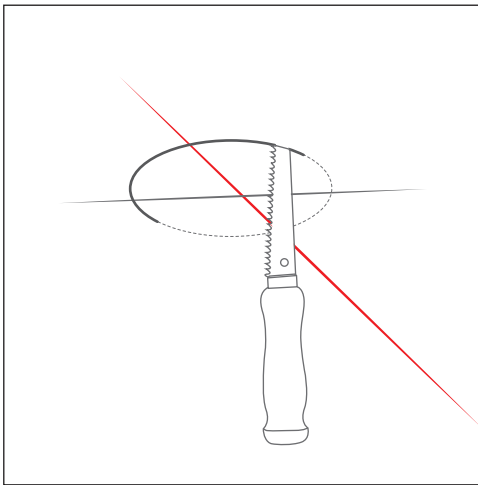

2B. IF REC CEILING PLATE
Make cutout using appropriate wallboard saw.

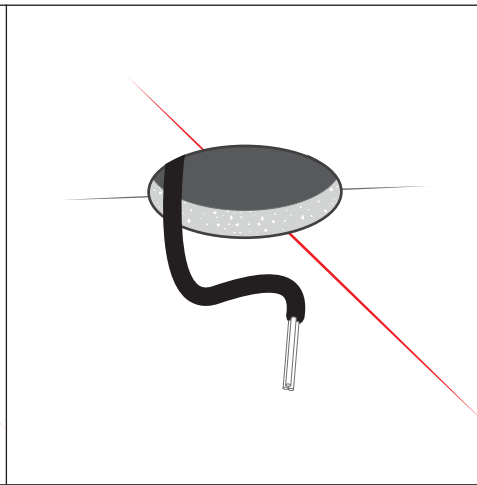

3B. IF REC CEILING PLATE
Pull powercable(240V) through cutout.

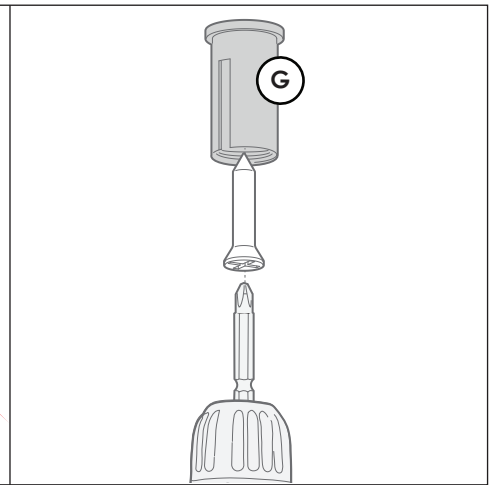

4.
Fix the posilock(G) onto the ceiling with appropriate fasteners (*not supplied*).

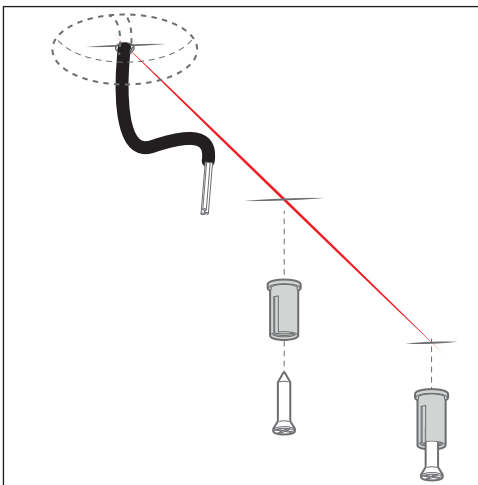

5. IF MULTIPLE SUSPENSIONS
Fix remaining posilock(G) onto the ceiling with appropriate fasteners (*not supplied*).

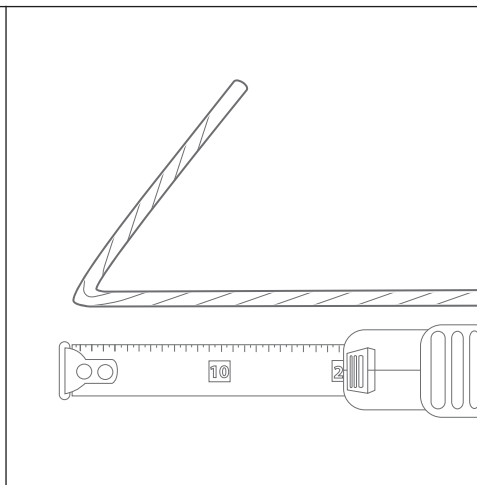

6.
Measure desired length of the Suspension wire(I). Lightly bend and crimp to mark desired length.

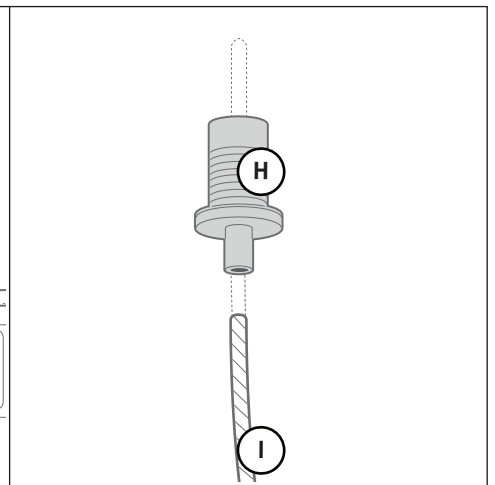

7.
Thread the Suspension wire(I) through wire gripper(H).

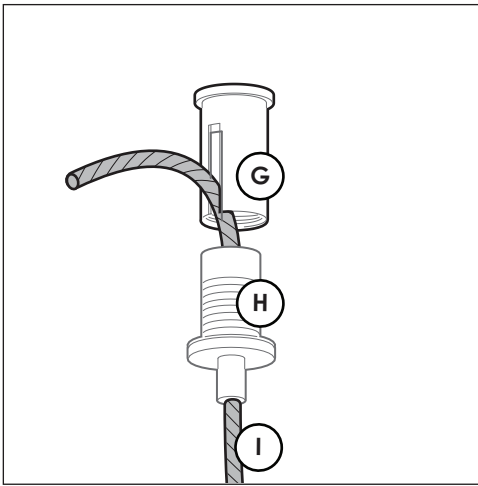

8. Insert excess wire(I) through slot & connect gripper(H) & posilock(G).

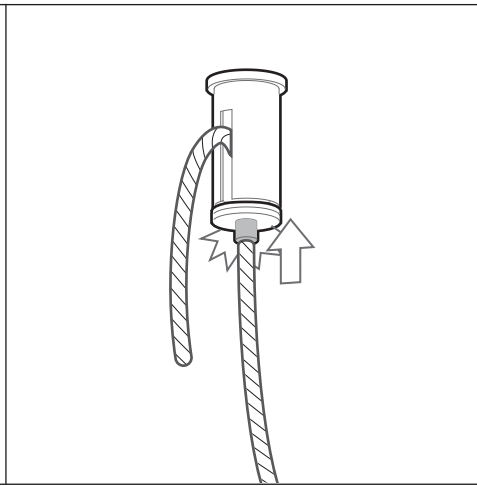

9. Press sprung tip and adjust suspension wire if required.

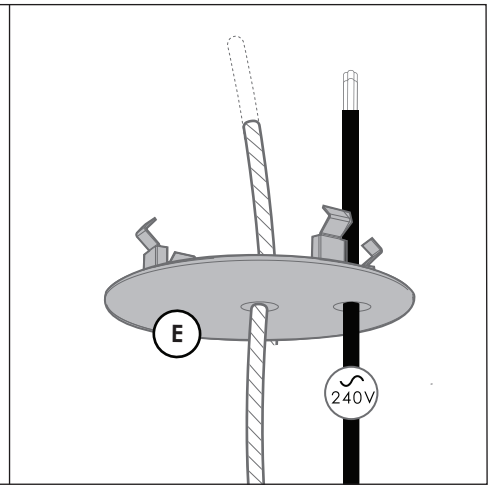

10. Pull supplied power cable(240V) through ceiling plate cover(E)

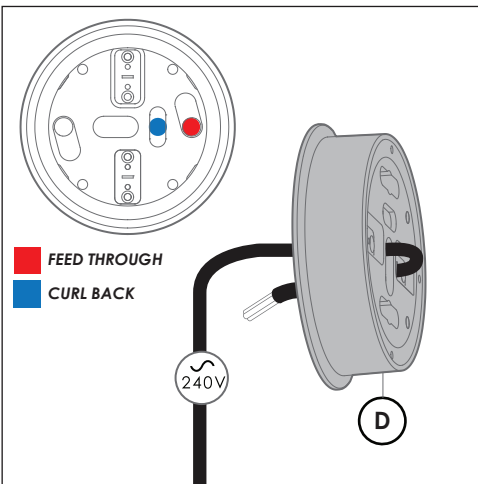

11. IF SM CEILING PLATE A
Thread supplied power cable (240V) through cable anchor. Curl back into cutout.

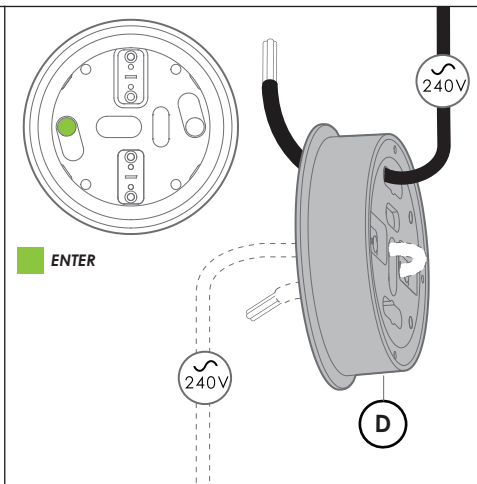

IF SM CEILING PLATE B
Insert pulled power cable(240V) through opposite cutout (see inset)

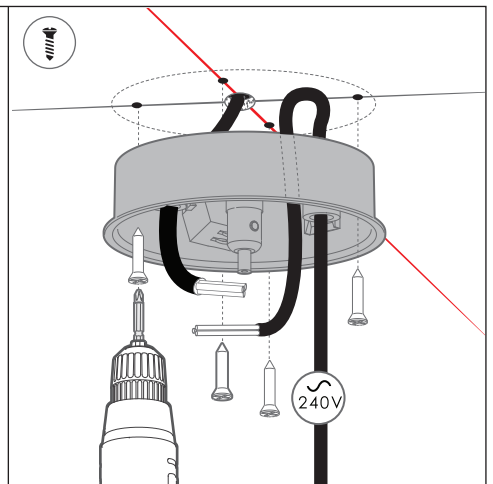

IF SM CEILING PLATE C
Fix ceiling plate (D) with appropriate fasteners (not supplied)

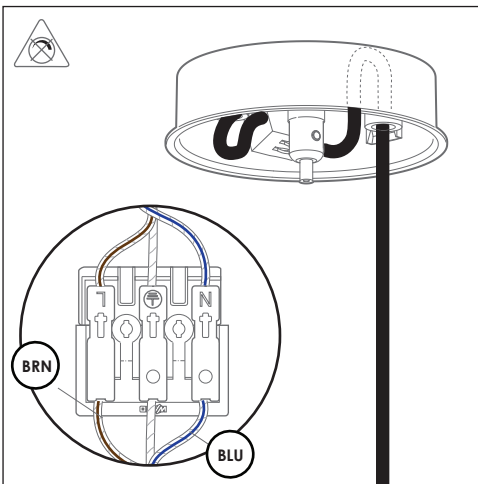

IF SM CEILING PLATE D (NON DIM)
Wire primary wires into terminal.

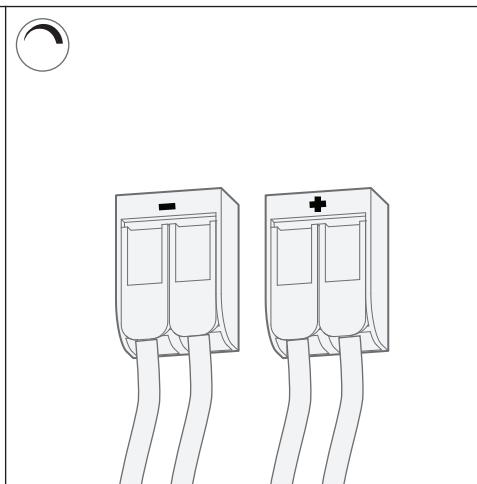

IF SM CEILING PLATE E (DIM)
Replicate step 7BA and connect dimming wires into wago terminal block, close.

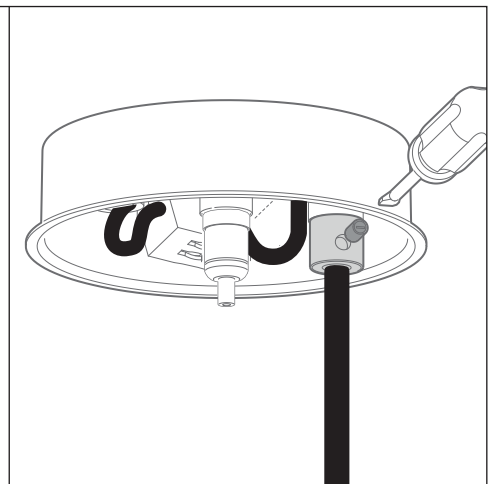

IF SM CEILING PLATE F
Fix 3mm grub screw into cable anchor with flathead driver.

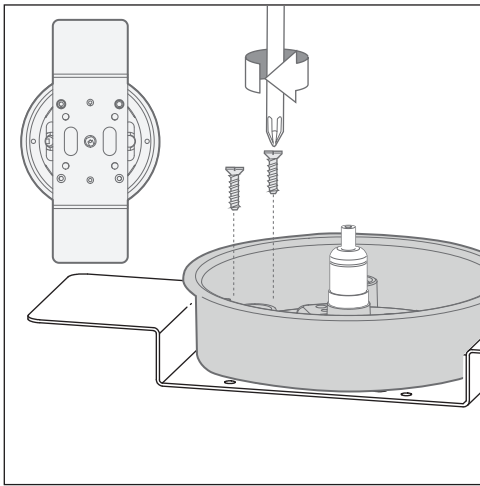

IF REC CEILING PLATE A
Align holes and install 2 of 4 bolts into one side of bracket(E).

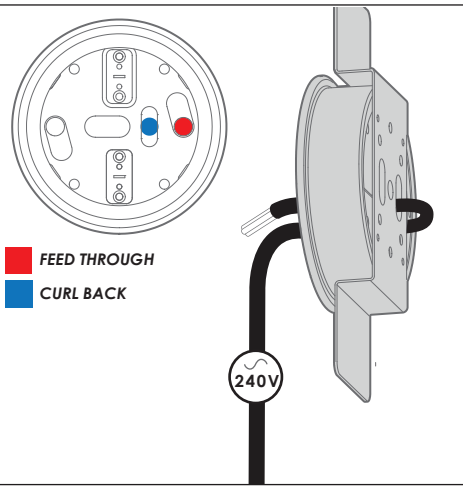

IF REC CEILING PLATE B
Thread supplied powercable (240V) through cable anchor & Bracket(G). Curl back into cutout.

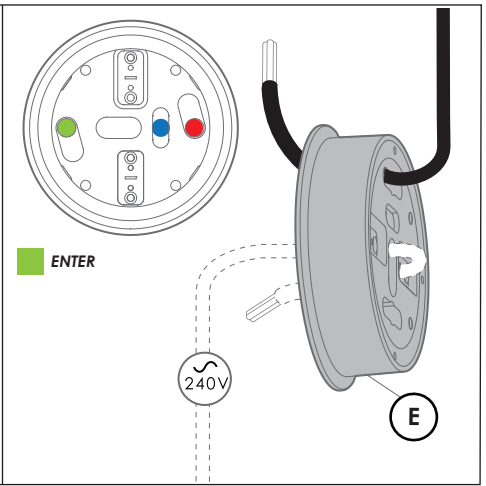

IF REC CEILING PLATE C
Insert pulled powercable(240V) through opposite cutout (see inset)

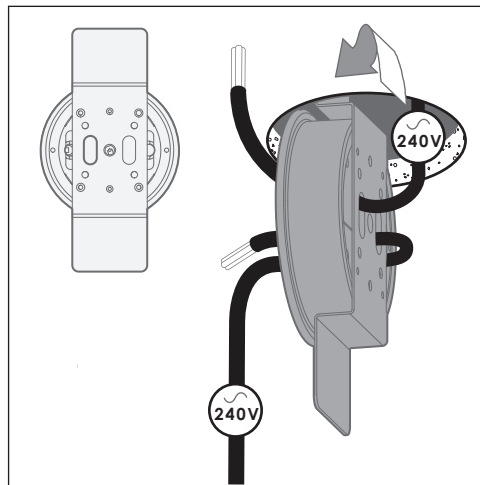

IF REC CEILING PLATE D
Insert the fixed ceiling plate(D) & bracket(F) into the cut. Ensure lip of ceiling plate sits proud of surface.

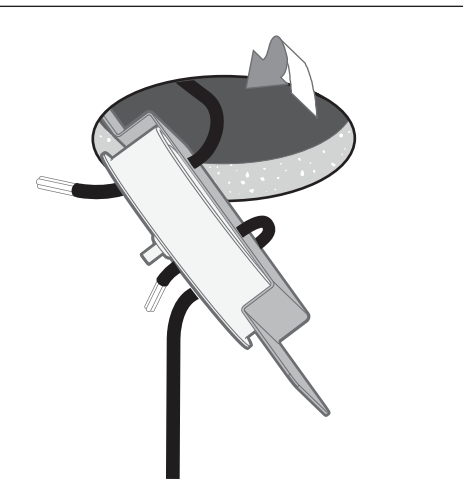

IF REC CEILING PLATE E
Step the fixed ceiling plate(D) & bracket(F) into the cutout.

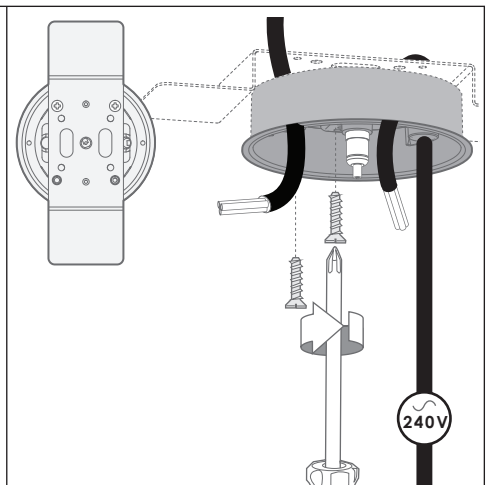

IF REC CEILING PLATE F
Fix the remaining side of the Ceiling plate(D) into bracket(F) with the remaining 2 bolts

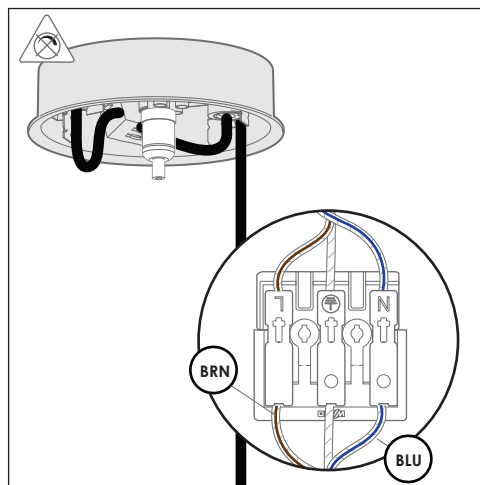

IF REC CEILING PLATE G(NON DIM)
Wire primary wires into terminal.

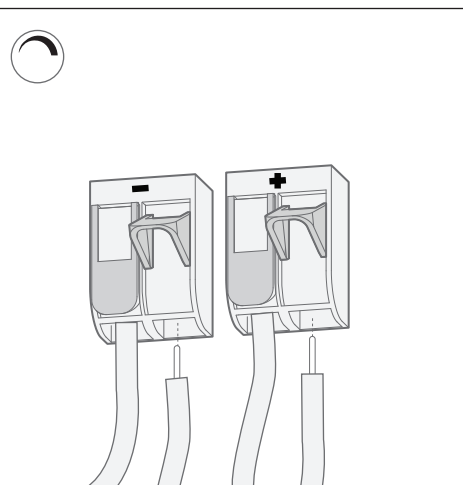

IF REC CEILING PLATE H(DIM)
Replicate step 7BA and connect dimming wires into wago terminal block, close.

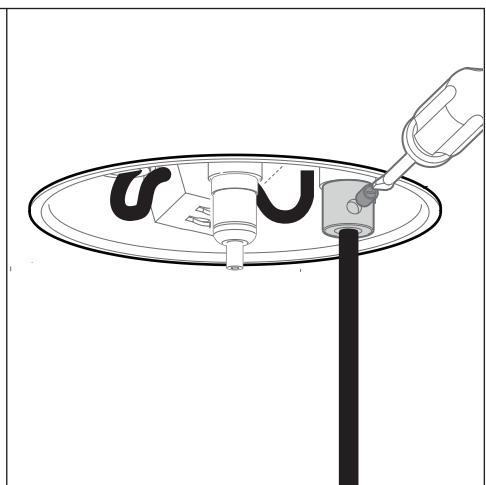

IF REC CEILING PLATE I
Fix 3mm grub screw into cable anchor with flathead driver.

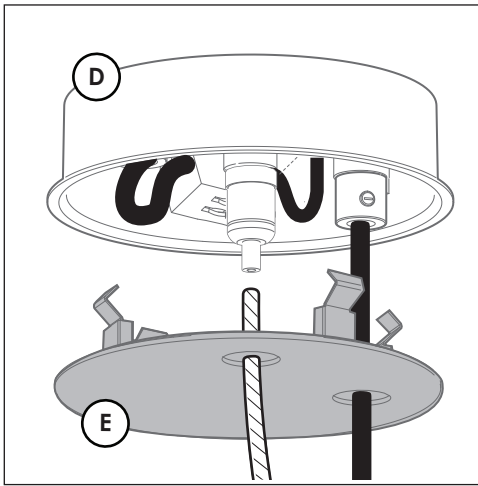

12. Attach cover (E) onto the Ceiling plate (D). Insert suspension wire into posilock.

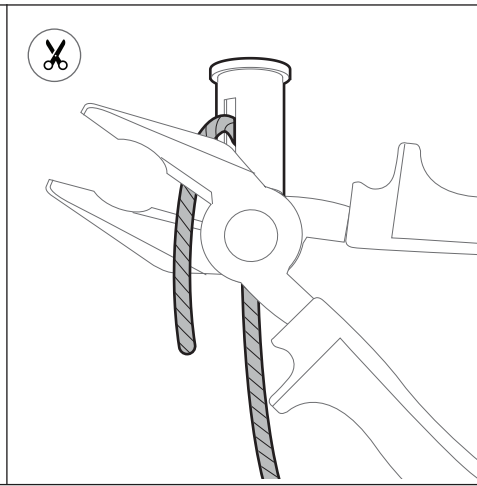

13. Using pliers, trim off excess suspension wire (I).

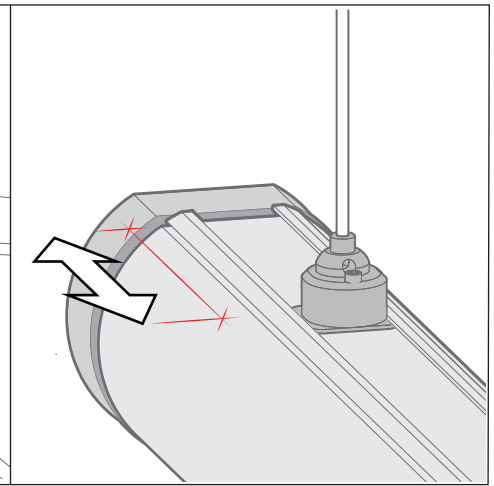

14. Ensure suspensions are positioned in appropriate location (see figure 1)

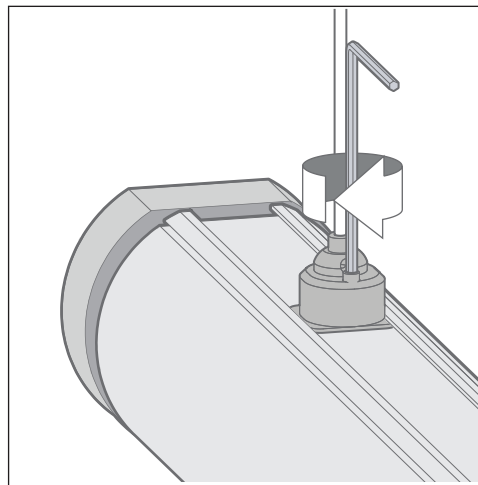

15. Ensure all suspension saddles (I) are fixed by using 3mm Allenkey.

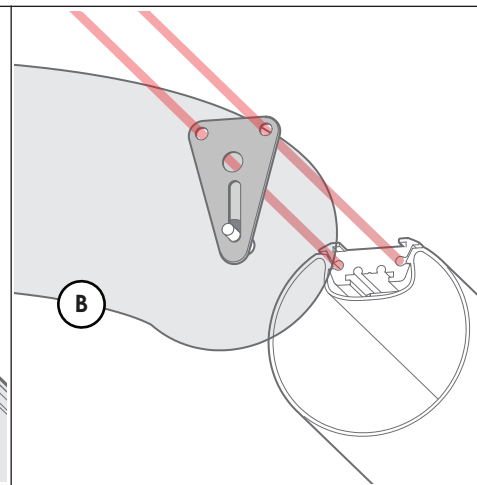

16. IF INSTALLING CORNERS
Align mounting plate w/ mainbody screw flute detail.

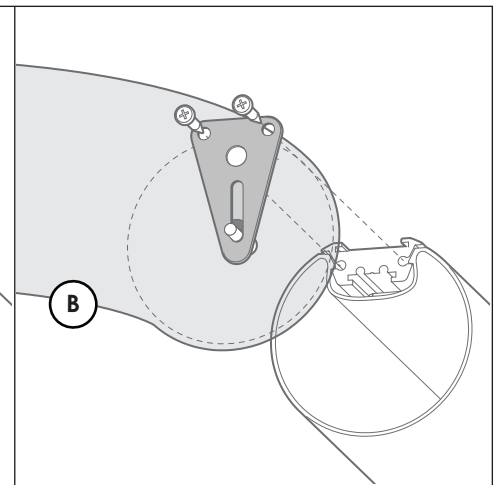

17. With supplied fastener, fix plate onto mainbody with screw driver.

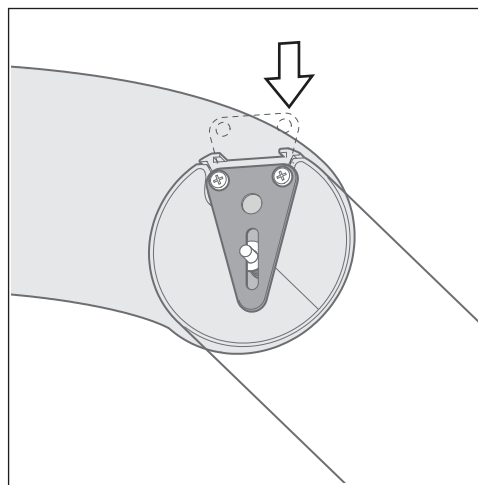

18. Slide plate and conceal into corner. Ensure Tube lens sits inside lip

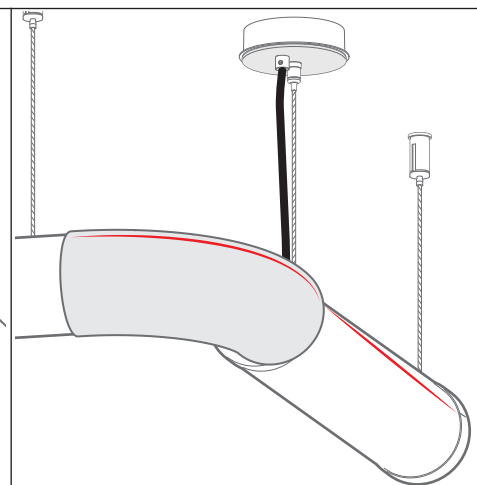

19. Use Laser to ensure fitting is straight and no light bleeds through join.

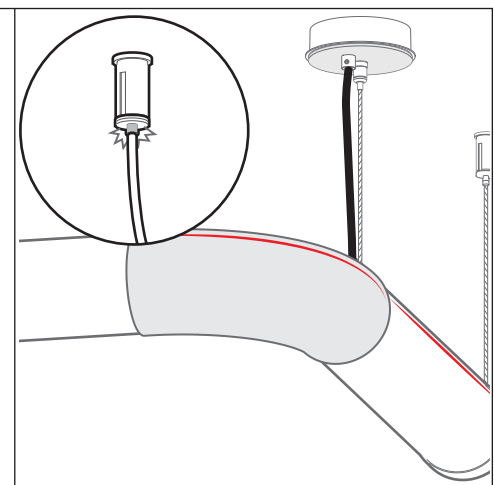

20. Press sprung tip and adjust suspension wire if required. Use laser to confirm bodies are square and levelled correctly.